

Označení dílů

M – fotoleptané kovové díly
D - obtisky
? - volba

Parts labelling

M – photoetched parts
D - decals
? - option

Zbarvení

Celé vozidlo bylo v tmavé zelené barvě

Camouflage

All vehicle was in dark green

Návod ke stavbě

Při stavbě postupujte podle instruktžních obrázků.

Instructions

Follow the instruction drawings the assembly.

Upozornění: Během opracování může vznikat prach, který může dráždit dýchací cesty. Používejte ochranu očí při odšťihování kovových dílů.

Notice: Machining can produce dust which can be irritating to the respiratory tract. Parts should be cut off using protection eyesight.

Kupujte přímo na www.plusmodel.cz
Buy directly from www.plusmodel.cz

Plus Model s.r.o
Jižní 56, 370 10 České Budějovice
Czech Republic
<http://www.plusmodel.cz>
e-mail: plusmodel@plusmodel.cz

312

plusmodel

1/35

M422 Command car



Historie

M422 „Mighty Mite“ byl malý, ¼ tunový terénní automobil s pohonem všech čtyř kol. Byl vyráběn pro U.S. Marine Corps od ledna 1960 do ledna 1963 ve dvou verzích v celkovém počtu 3922 kusů. Velitelské vozy byly vybaveny kulometem M60 a vysílačkou.

Technická data

M422 : Rám podvozku	165 cm
Celková délka	272 cm
Šířka	155 cm
Výška	152 cm
Max. rychlost	99 km/h

Verze M422A1 měla o 15 cm delší karoserii a rám podvozku.

History

The M422 „Mighty Mite“ was a very small quarter-ton four-wheel drive truck built for U.S. Marine Corps from January 1960 to January 1963. 3922 units were produced in two versions. Command cars were equipped with machine gun M60 and transmitter.

Technical data

M422 : Wheel base	65 in.
Overall length	107 in.
Width	61 in.
Height	60 in.
Max. speed	62 mph

M422A1 version had a six-inch longer body and wheel base.

1

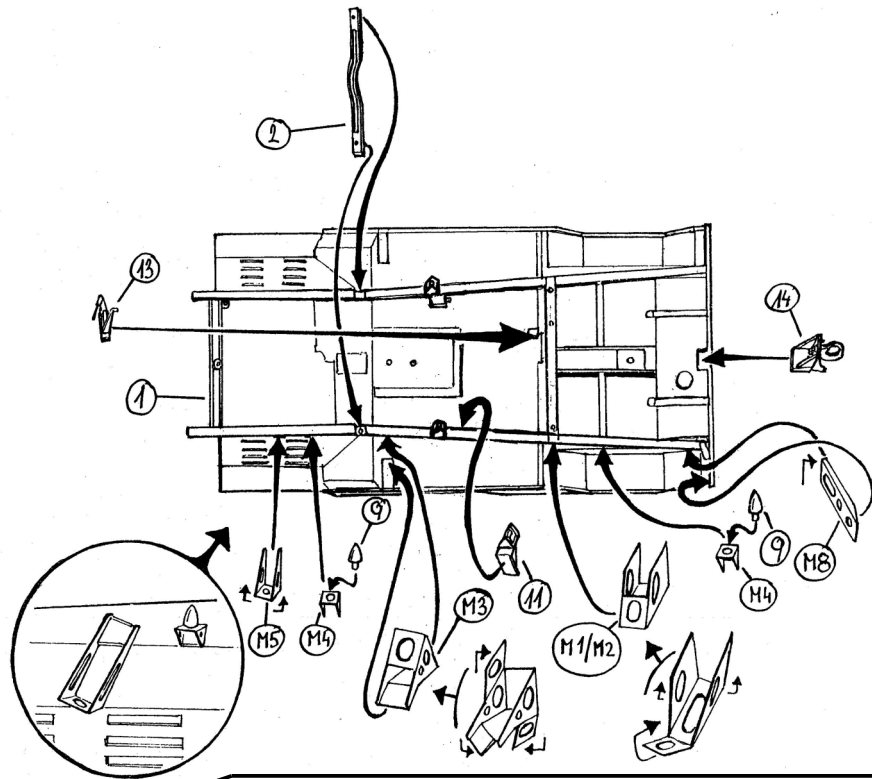

2

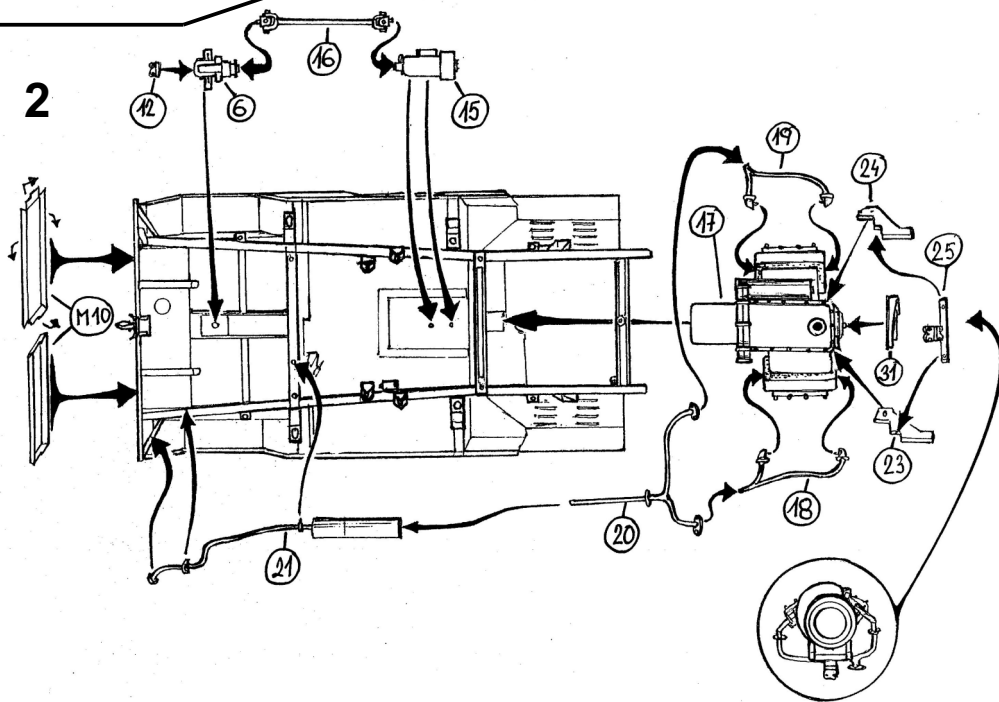

Marking

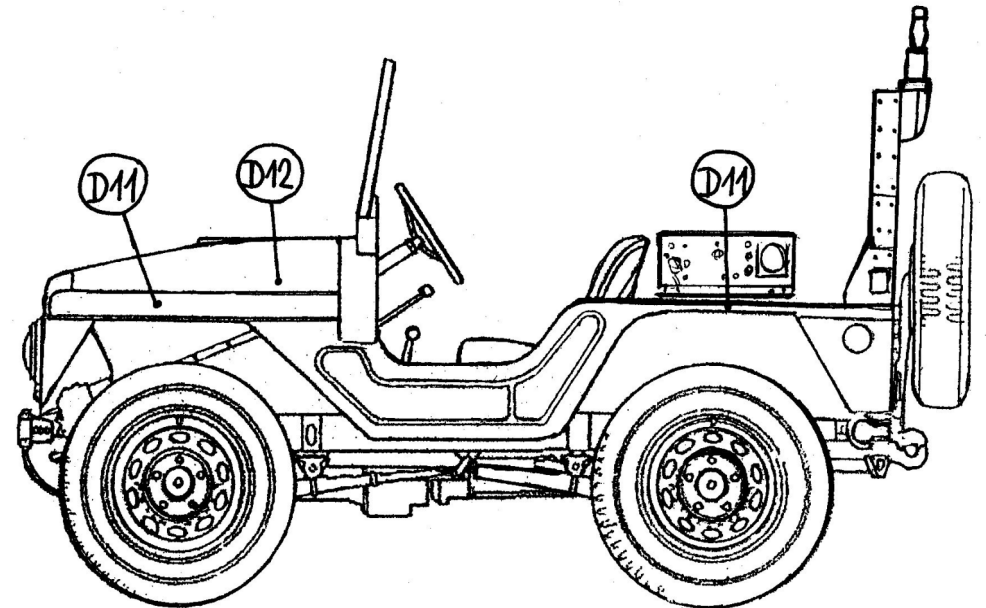
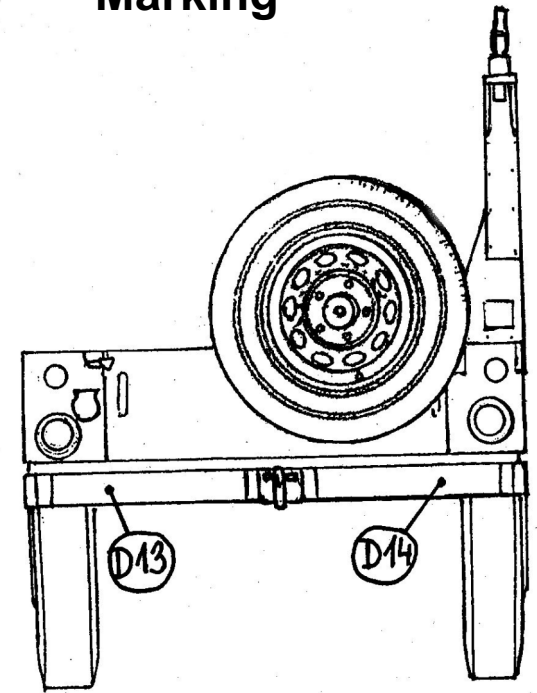

16

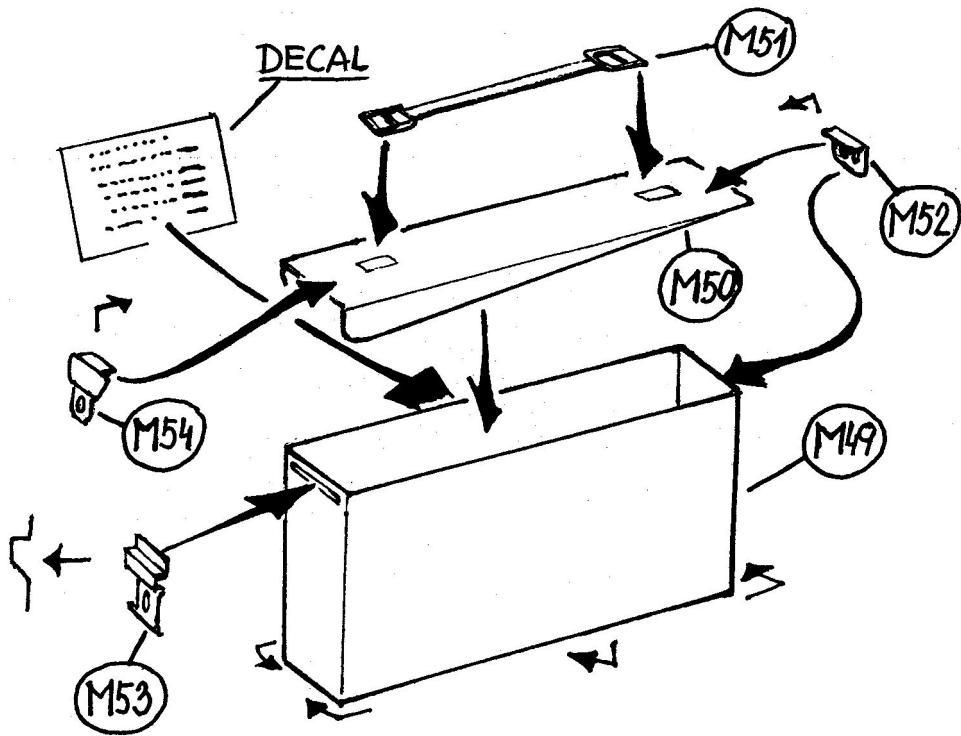

3

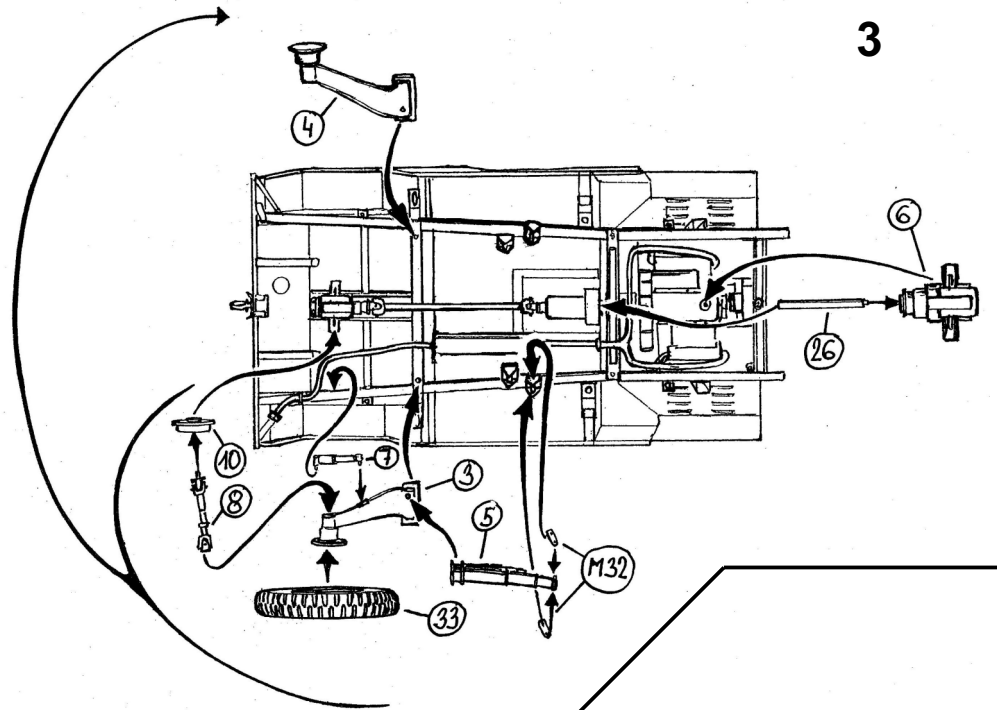

4

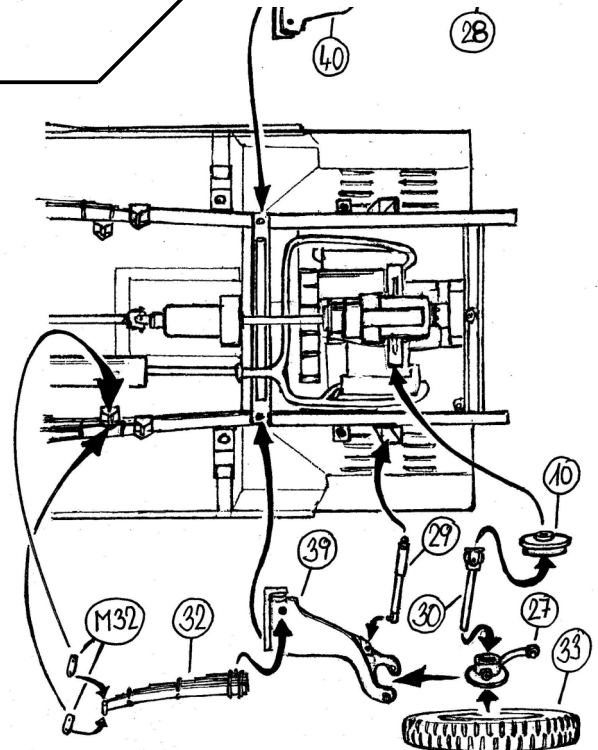

5

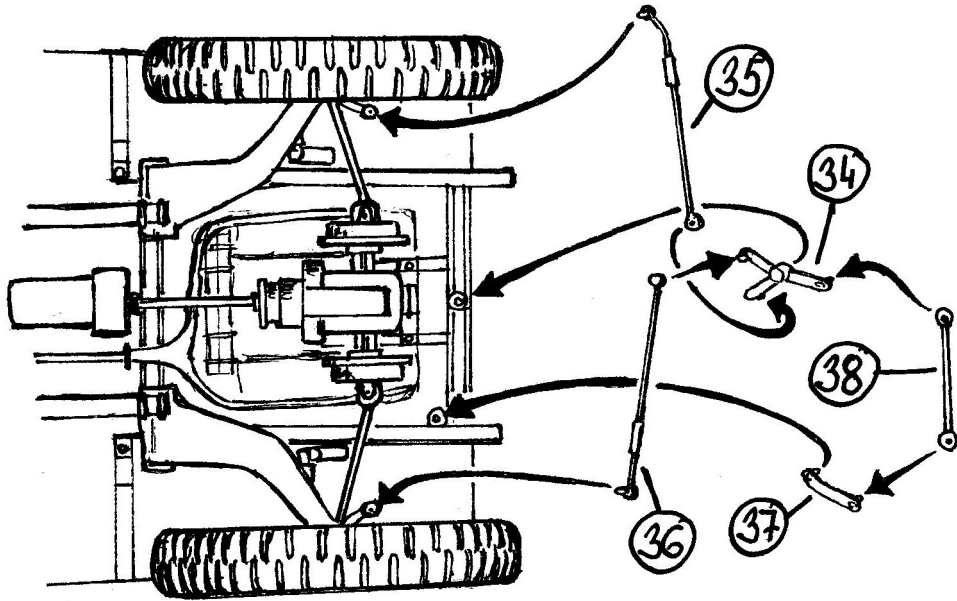

14

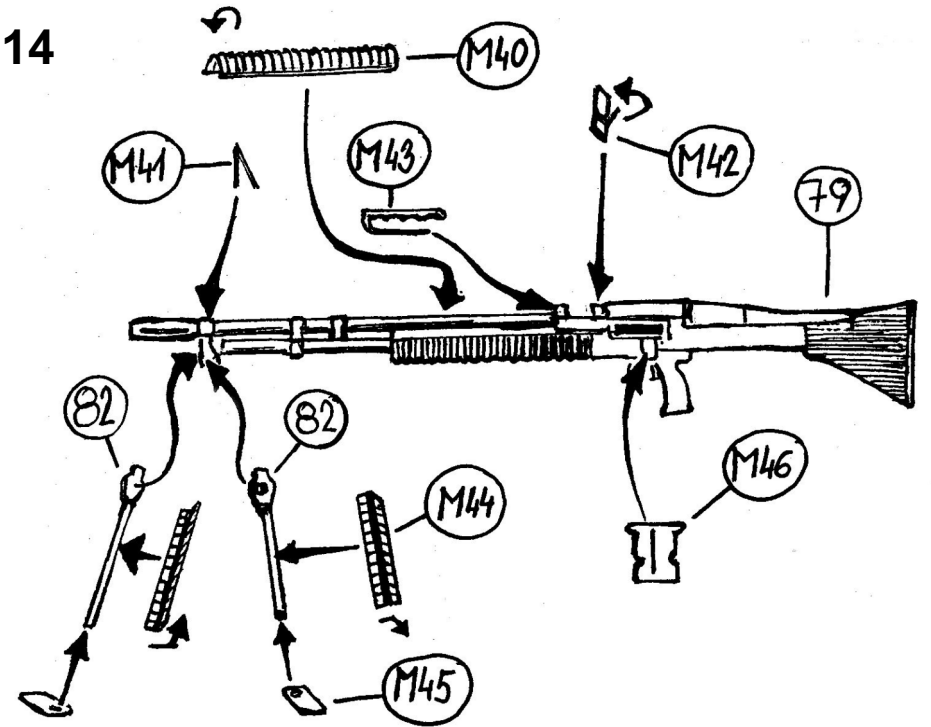

6

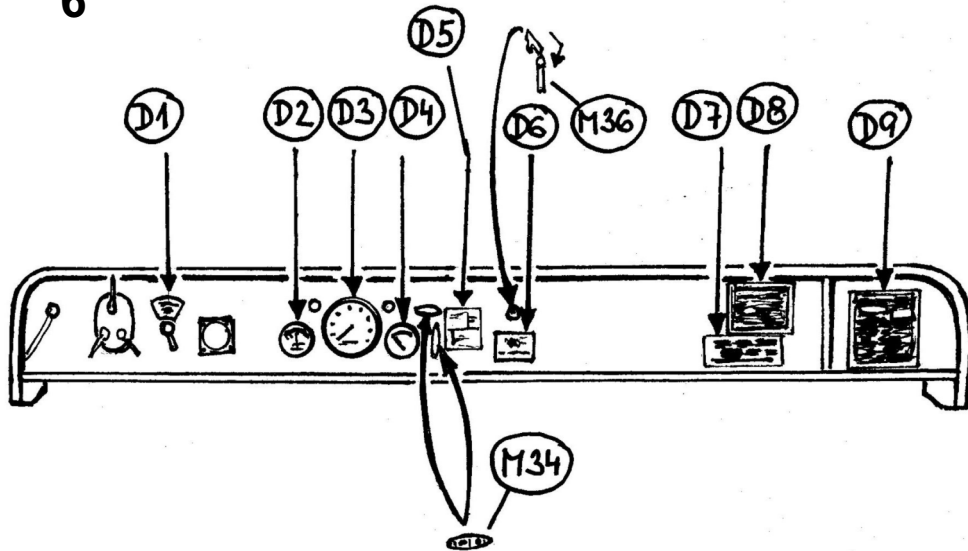

15

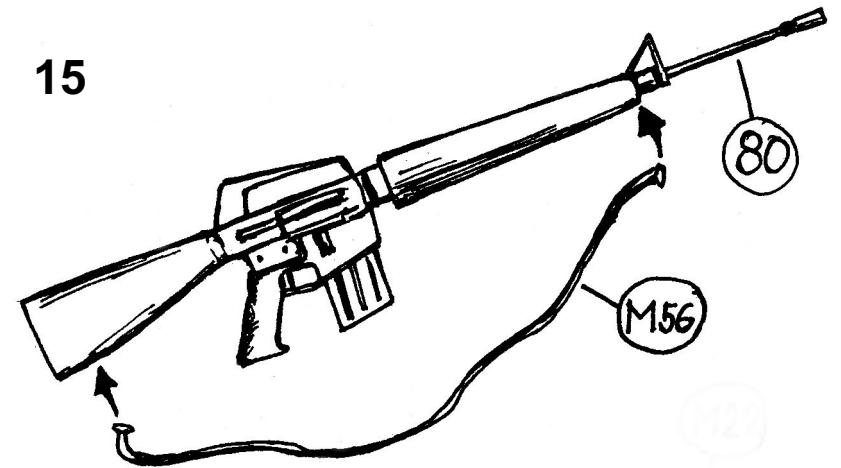

12

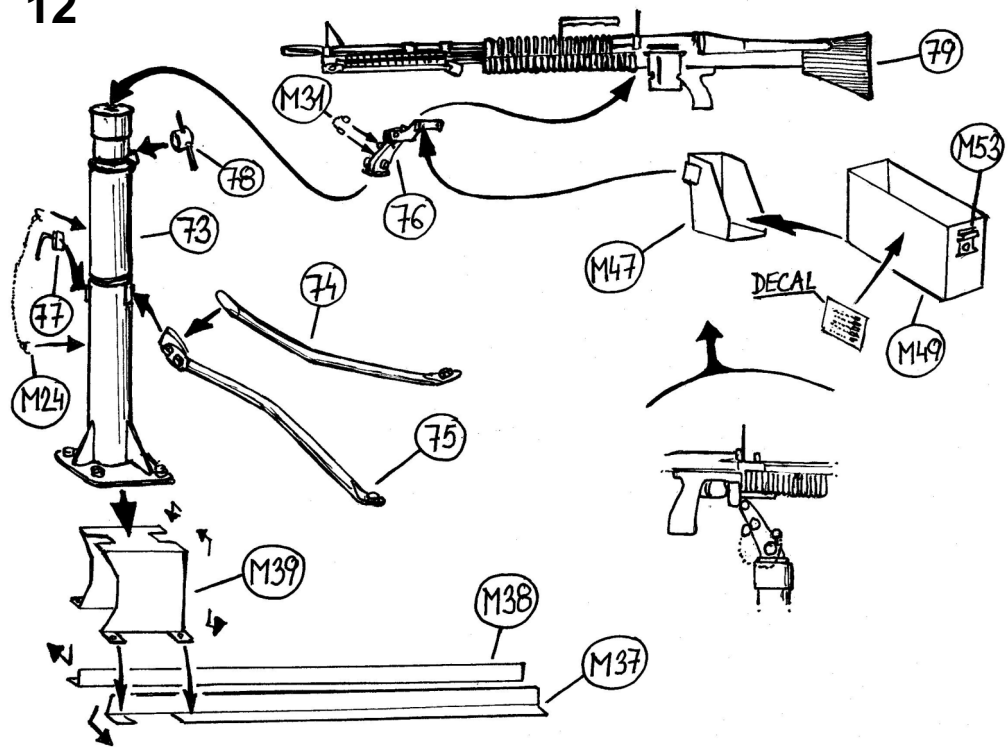

13

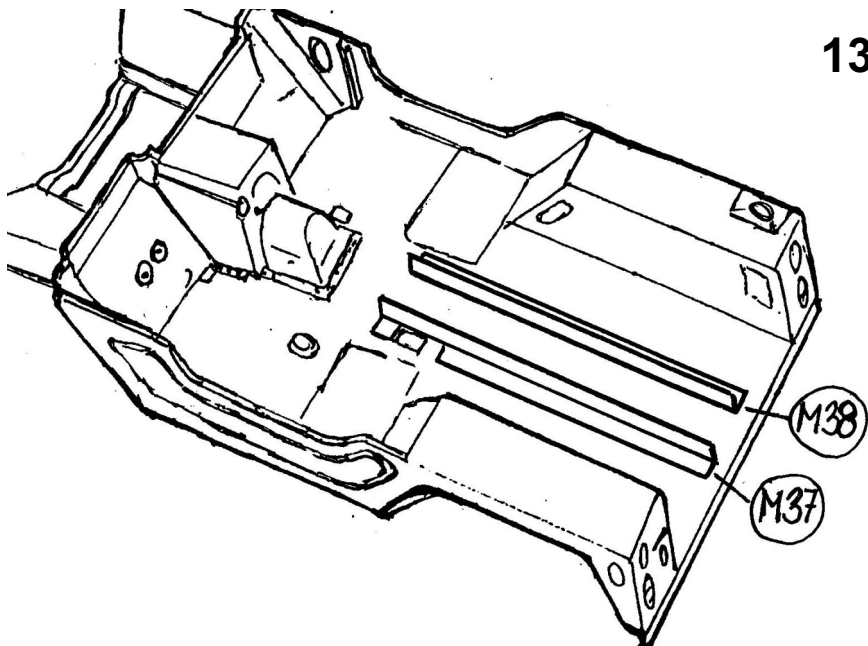

7

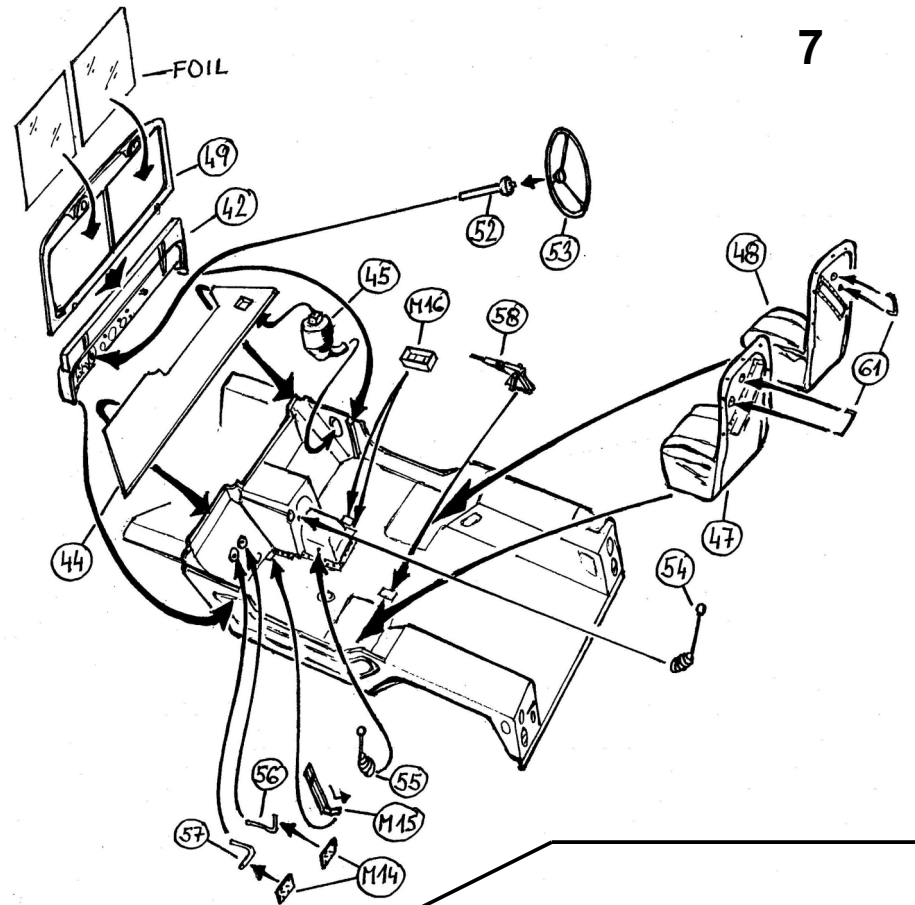

8

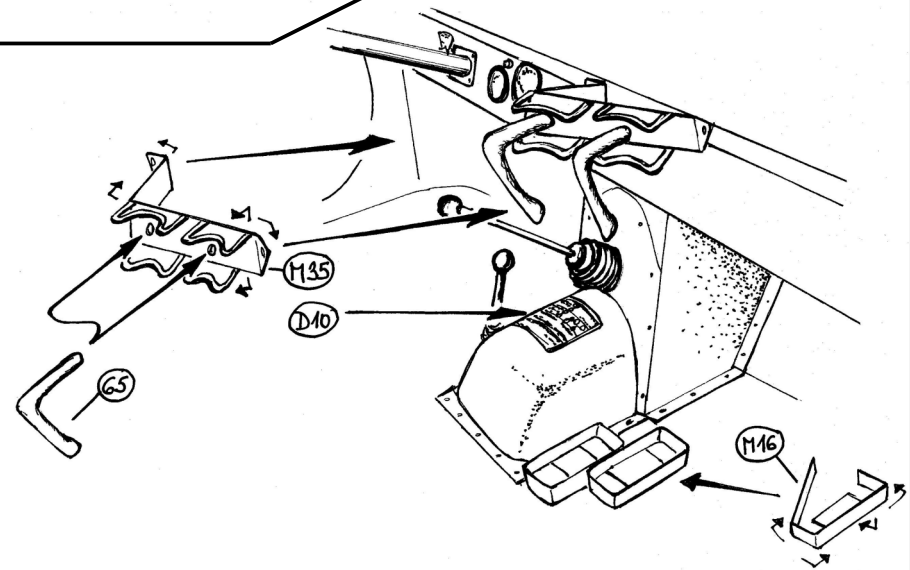

9

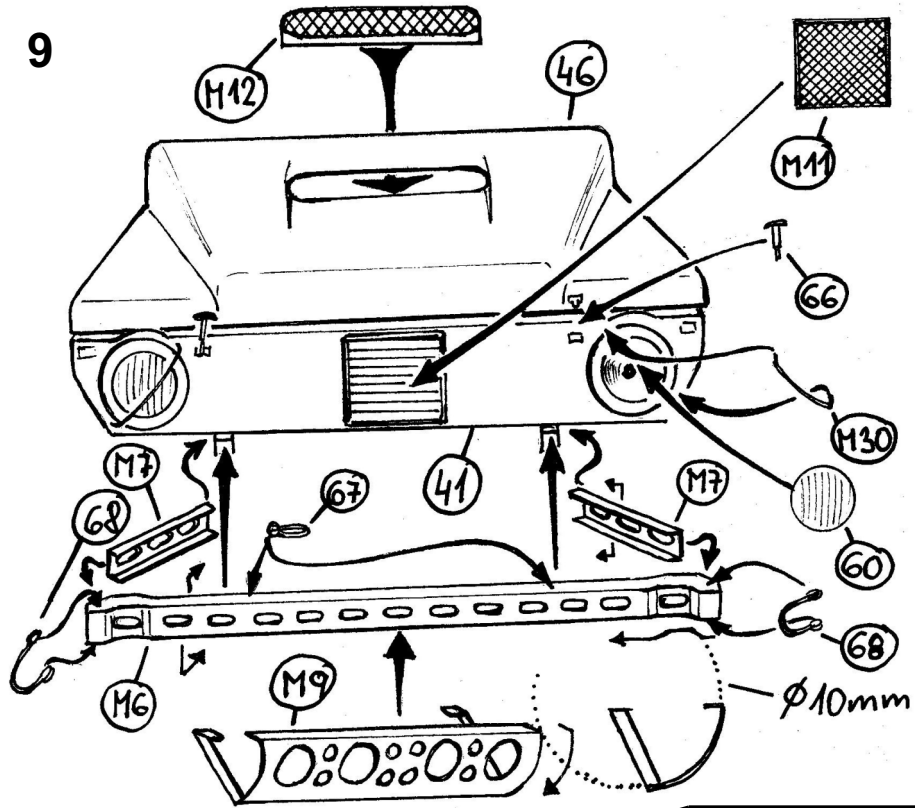

10

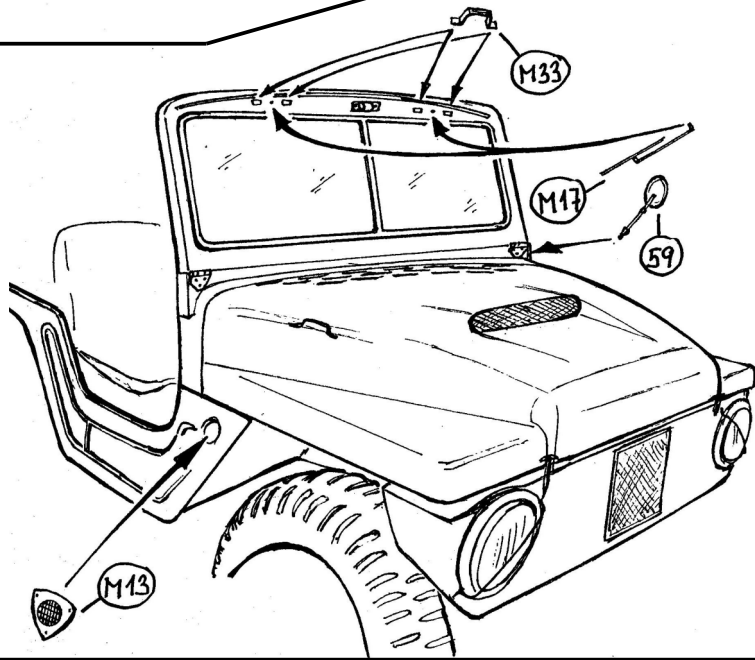

11

